

# Fixtures for Edge, Flat and Ring Crush Testing (ECT, FCT, RCT)

A number of test methods and standards employed by various industry bodies call upon specific crush fixtures and associated accessories to be used in conjunction with a compression tester. Mecmesin has developed a range of ECT, FCT and RCT fixtures to meet the demands of the most commonly used standards for testing paper, paperboard, fibreboard, and corrugated fibreboard.

Part No.	Description	QC Connection
PDV14137	Edge Crush Test - Guide Blocks (20 mm x 20 mm x 100 mm)	N/A
PDV11089	Flat Crush Test - Upper & Lower Plates (120 mm square) with modified Anvil Plate and Self-Adjusting Adapter	N/A
PSV21099	Ring Compression Test - Carrier plus Ring Compression Test Insert (select from $\phi 45.3$ mm, $\phi 47.8$ mm, $\phi 48$ mm, $\phi 48.2$ mm)	N/A
PSV21062	Crush Test Fixture with Precision Guide - aids testing to ISO3037, ISO12192, TAPPI T822 and T811	Yes - QC 20, QC 32



PDV14137 ECT

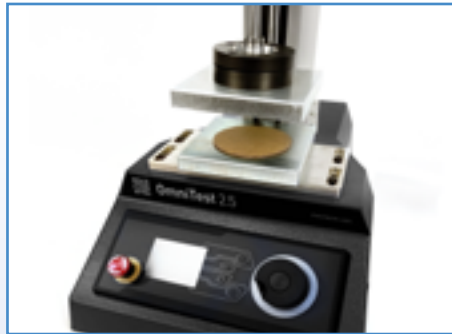

PDV11089 FCT



PSV21099 RCT

## Edge (Edgewise) Crush Test (ECT) of corrugated fibreboard

- Sample and condition the fluted (corrugated) fibreboard.
- Cut/prepare test pieces, enough for 10 tests. Sizes and shapes of the test pieces vary.
- Rectangular; 25.0 mm in height (direction of flutes) and 100.0 mm in length (perpendicular).
- Square; 50.8 mm.
- 'Neckdown' (hourglass) shape of height 50.8 mm, length reduced to 25.4 mm midway between the loaded edges.
- Place the test piece on the lower platen. Support it by placing a guide block on each side.
- The guide blocks may be moved away from the test piece when the load reaches about 50 N.
- Operate the compression tester at the required speed (12.5 mm/min) until the test piece fails.
- Record, to the nearest 1 N, the maximum force,  $F_{max}$ , developed up to the moment when instant failure occurs.
- Calculate the edgewise crush resistance  $R$ , expressed in kN per metre, using the equation  $F_{max}/l$ , where  $l$  = test piece length.



▲ PDV14137 Edge Crush Test Guide Blocks shown attached to PDV11089 Anvil Plate with rectangular fibreboard test pieces.

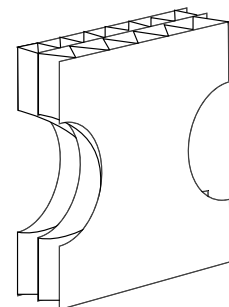

▲ 'Neckdown' shape double-wall fibreboard test piece, cut to ensure failure at the height mid-point.

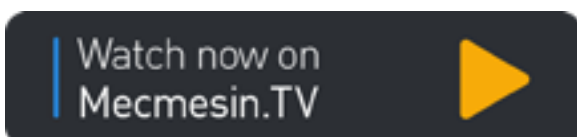

## Flat Crush Test (FCT) of corrugated board (rigid support method)

- Sample and condition the fluted (corrugated) fibreboard appropriately.
- Cut/prepare circular test pieces enough for 10 tests (as follows).
- Sizes of the test pieces may vary: 32.3 cm<sup>2</sup>, 50.0 cm<sup>2</sup> or 64.5 cm<sup>2</sup>, at least 38 mm clear from printed matter, scores, die-cuts or other features.
- Place the test piece centrally onto the lower platen.
- Operate the compression tester until the fluting collapses. If the fluting leans sideways, repeat the test until symmetrical crush is achieved.
- Record, to the required resolution, the maximum force,  $F_{max}$ , sustained before complete collapse.
- Calculate the flat crush resistance  $R$ , expressed in kilopascals using the equation  $F_{max}/A$ , where  $A$  = test piece area.

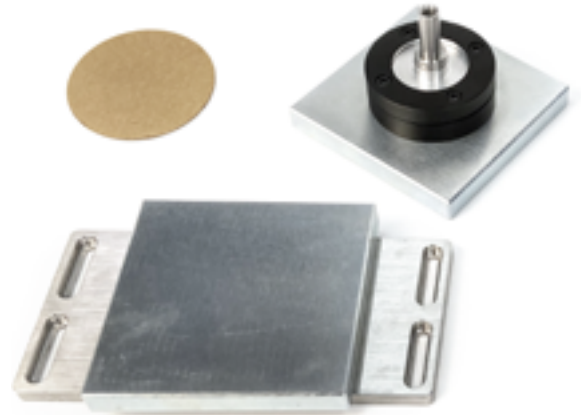

▲ PDV11089 Upper and Lower Compression Plates and self-levelling adapter with circular test piece.

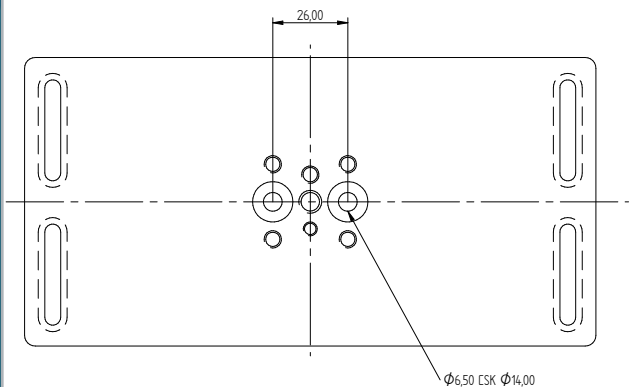
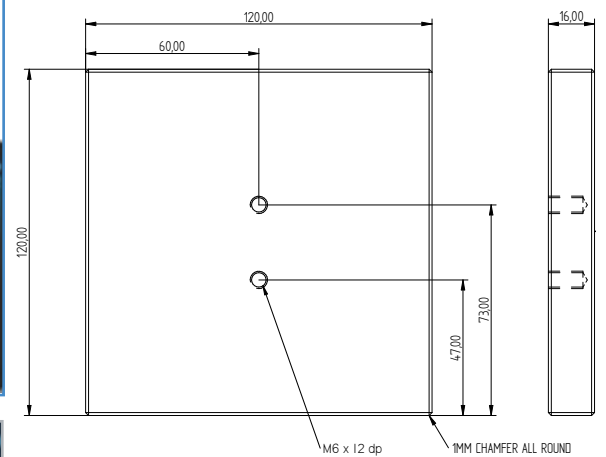
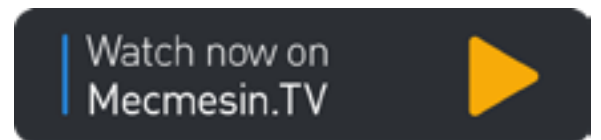
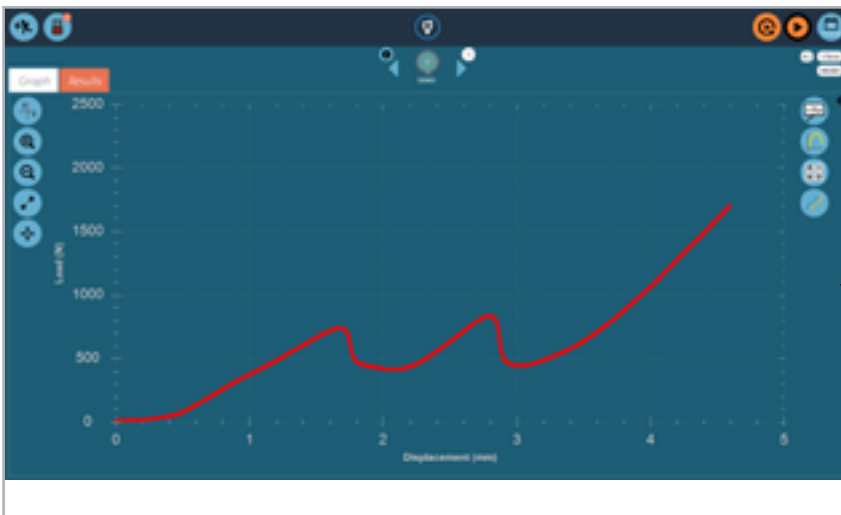

## Ring Crush Test paperboard to a compressive force when held in a ring shape.

- Sample and condition the paperboard appropriately. Avoid contamination by wearing gloves.
- Cut/prepare rectangular test pieces enough for 10 tests (as follows).
- Rectangular test pieces 12.7 mm wide, 152.4 mm long. Align appropriately to test Machine Direction or Cross Direction crush resistance.
- Mount the test piece in the ring fixture with insert selected for thickness, and at least 12.7 mm clear of the branch groove.
- Position the ring fixture on the lower platen, located consistently for every test replication (e.g., specimen ends facing the operator).
- Operate the compression tester to apply force via the Upper Compression Plate at the required speed (12.5 mm/min) until the test piece fails.
- Calculate the ring crush resistance  $R$ , expressed in kilonewtons per metre, by factoring from the measured peak force and the sample length of 152.4 mm (0.00656 for newtons).

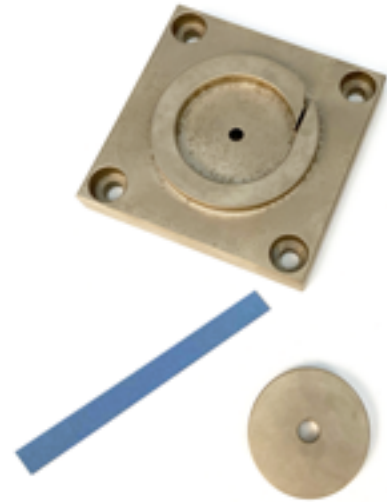

▲ PSV21099 Ring Compression Test Carrier and island Insert with rectangular test piece. To be used with Upper Compression Plate (50 mm x 50 mm square - order separately).

Watch now on  
Mecmesin.TV



## Crush Test Fixture featuring Precision Guide

Precise alignment of the upper compression plate with the test piece is essential for optimum accuracy of results. Mecmesin recommends a minimum of self-adjusting compression plates and, for ECT and RCT tests, the Crush Test Fixture featuring a Precision Guide mechanism.

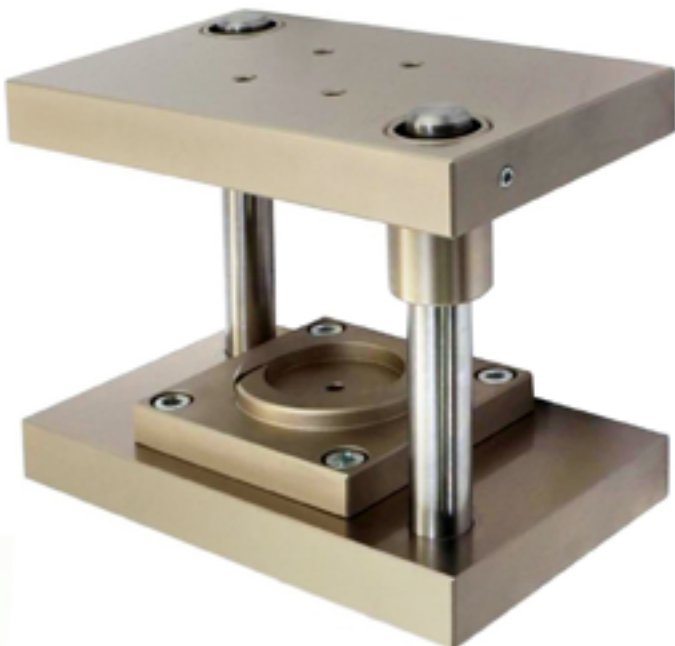

▼ PSV21062 Crush Test Fixture with Precision Guide. Ensures accurate alignment during compression to facilitate testing to ISO3037, ISO12192, TAPPI T822 and T811. May be combined with ECT, FCT and RCT fixtures (order separately). Shown here with RCT lower carrier.



▲ PSV21062 Crush Test Fixture with Precision Guide. Shown here with ECT Guide Blocks (order separately) for ISO3037 and TAPPI T811.

## Additional Accessories



◀ Manual (and hydraulic) presses are available to die-cut test pieces consistently to exact dimensions specified by the test standards.



Mec

+44 (0)1403 799979 | [mecmesin.com](http://mecmesin.com) | [info@mecmesin.com](mailto:info@mecmesin.com)