

Cable Tie Break Fixture for CrimpTest-1 kN



▲ 432-653 Cable tie fixture



▲ Shown in use on the CrimpTest-1 kN

Description

The cable tie break fixtures provide stepped bollards for testing tensile strength, with 10 mm-high steps for three tie lengths. They are mounted in place of the standard rotating crimp receptacle and cam grip of the CrimpTest 1 kN.

Specification

Part no.	Description	Min. tie length in start position	Max. tie length in start position	Load rating
432-653	Cable tie break fixture for CrimpTest-1 kN	280 mm (11")	400 mm (15.75")	1 kN

Dimensions mm (inch)

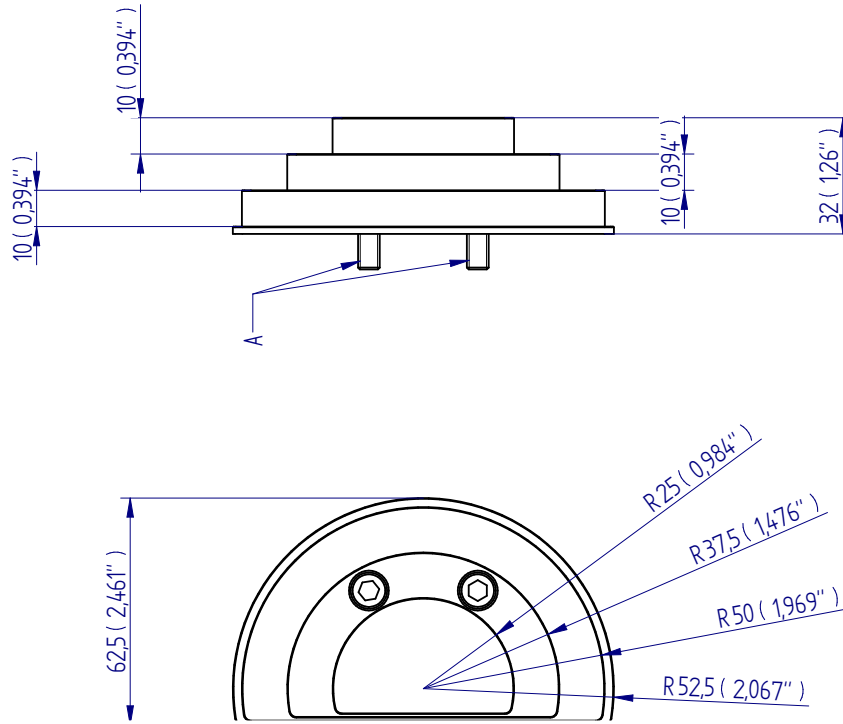

FS 58553

Mecmesin reserves the right to alter equipment specifications without prior notice.

E&OE

DISTRIBUTOR STAMP

Head Office - UK
Mecmesin Limited

w: www.mecmesin.com
e: sales@mecmesin.com

North America
Mecmesin Corporation

w: www.mecmesincorp.com
e: info@mecmesincorp.com

France
Mecmesin France

w: www.mecmesin.fr
e: contact@mecmesin.fr

Asia
Mecmesin Asia Co., Ltd

w: www.mecmesinasia.com
e: sales@mecmesinasia.com

Germany
Mecmesin GmbH

w: www.mecmesin.de
e: info@mecmesin.de

China
Mecmesin (Shanghai) Pte Ltd

w: www.mecmesin.cn
e: sales@mecmesin.cn